

Points in Three Dimensions

Describe the location of each point in relation to the origin.

1) $(4, 0, 3)$

2) $(2, -3, 3)$

3) $(-1, 3, 4)$

4) $(-2, 4, 4)$

5) $(1, -3, 4)$

6) $(0, -2, -4)$

Write the coordinates of each point.

7)

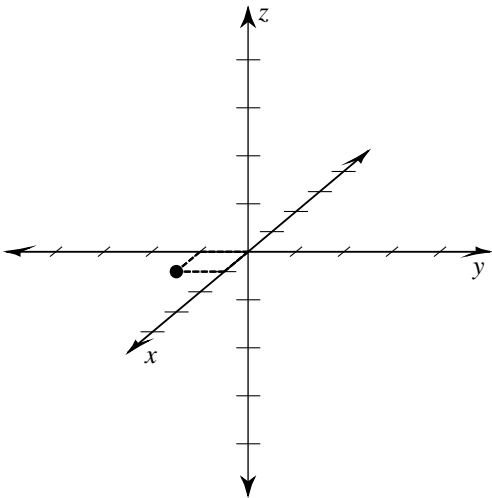

8)

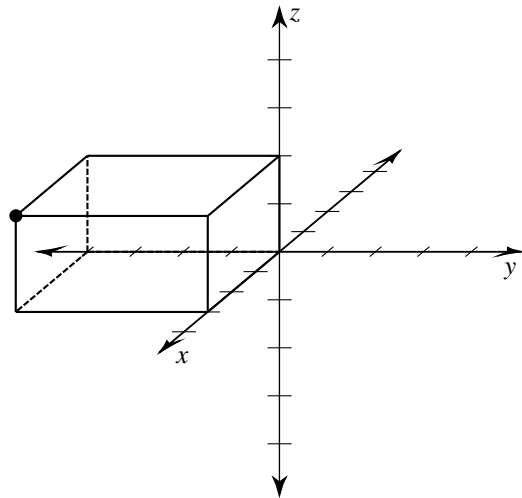

9)

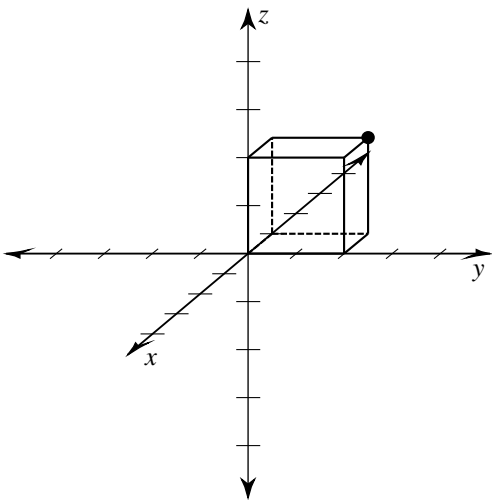

10)

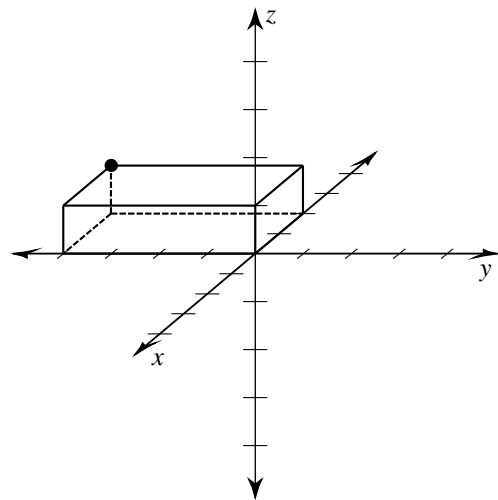

Plot each point.

11) $(-1, -4, -1)$

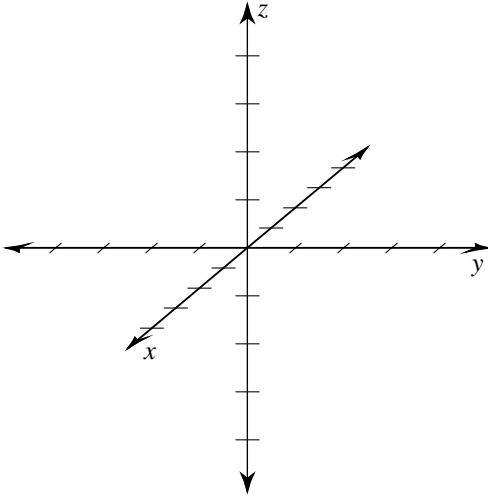

12) $(3, -1, -1)$

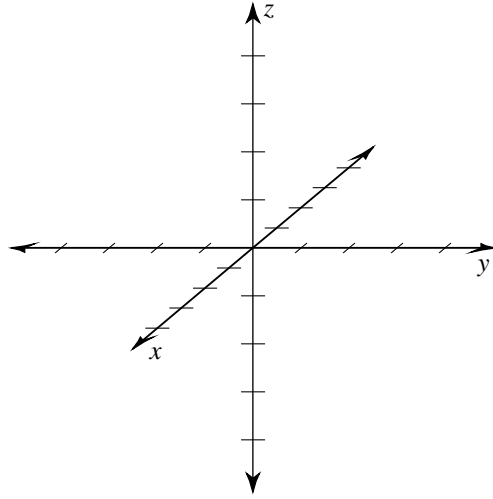

13) $(-1, -3, 1)$

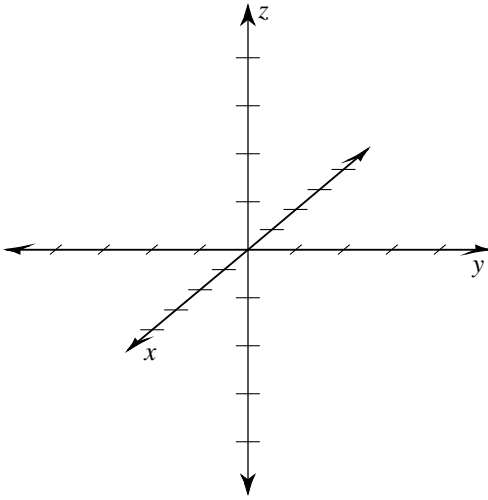

14) $(-3, 2, -2)$

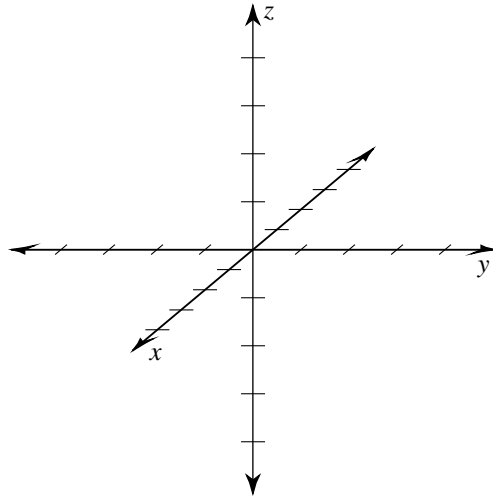

15) $(-4, 3, 0)$

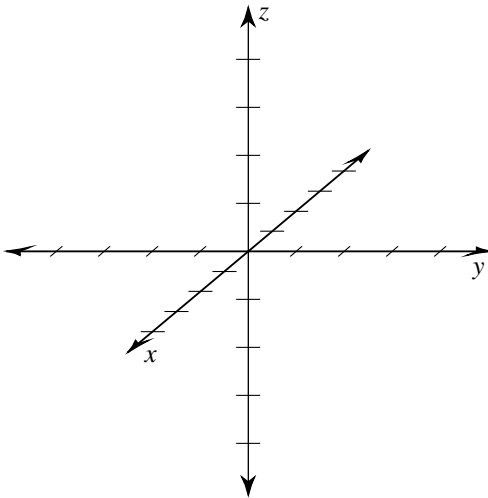

16) $(-4, -4, 3)$

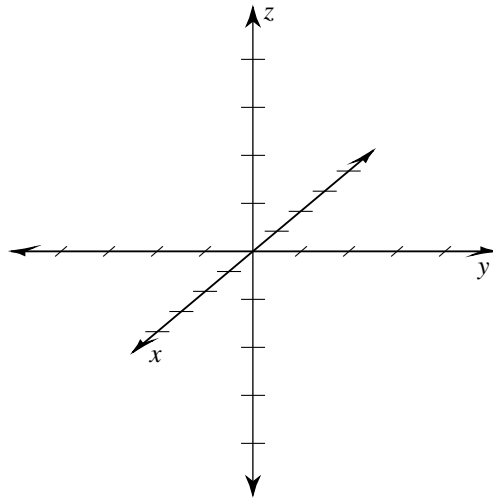

Points in Three Dimensions

Describe the location of each point in relation to the origin.

1) $(4, 0, 3)$

4 forward, 3 up

2) $(2, -3, 3)$

2 forward, 3 left, 3 up

3) $(-1, 3, 4)$

1 back, 3 right, 4 up

4) $(-2, 4, 4)$

2 back, 4 right, 4 up

5) $(1, -3, 4)$

1 forward, 3 left, 4 up

6) $(0, -2, -4)$

2 left, 4 down

Write the coordinates of each point.

7)

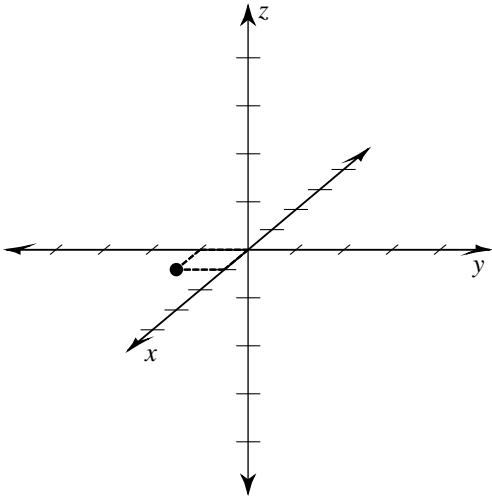

$(1, -1, 0)$

8)

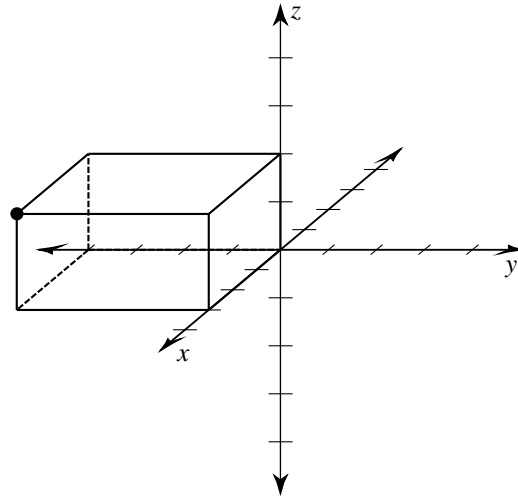

$(3, -4, 2)$

9)

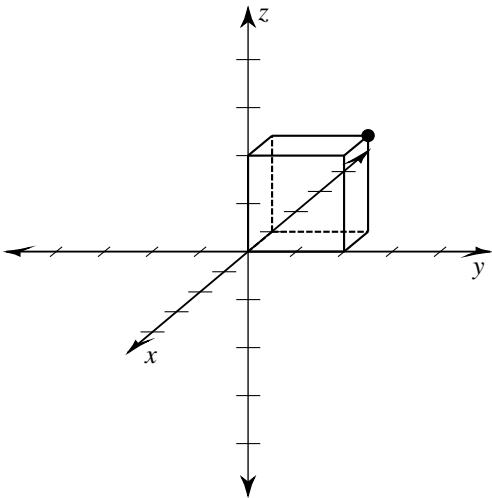

$(-1, 2, 2)$

10)

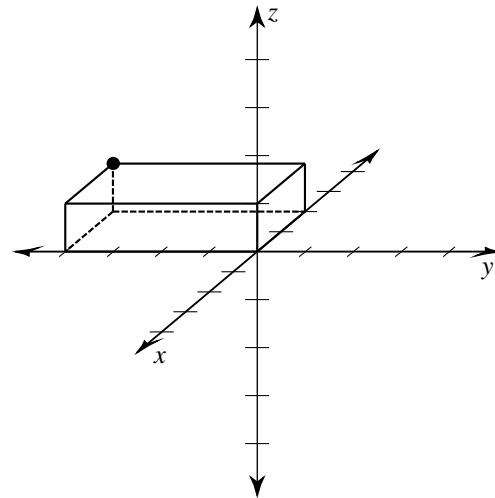

$(-2, -4, 1)$

Plot each point.

11) $(-1, -4, -1)$

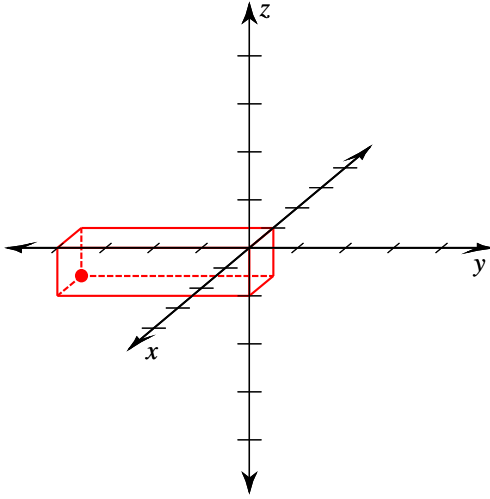

12) $(3, -1, -1)$

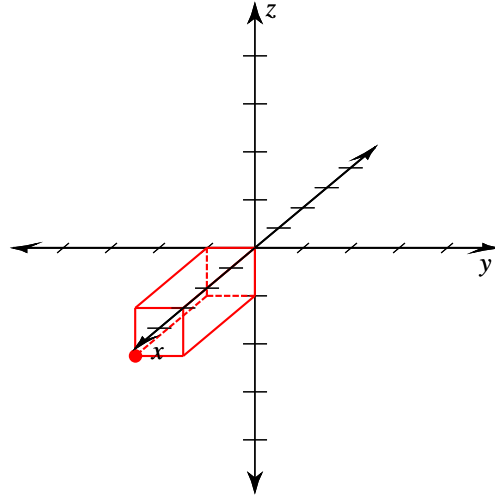

13) $(-1, -3, 1)$

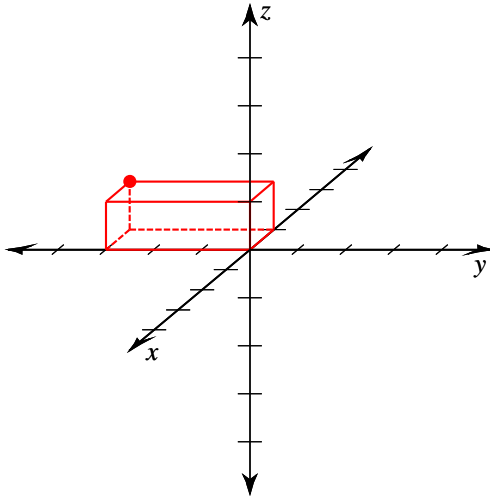

14) $(-3, 2, -2)$

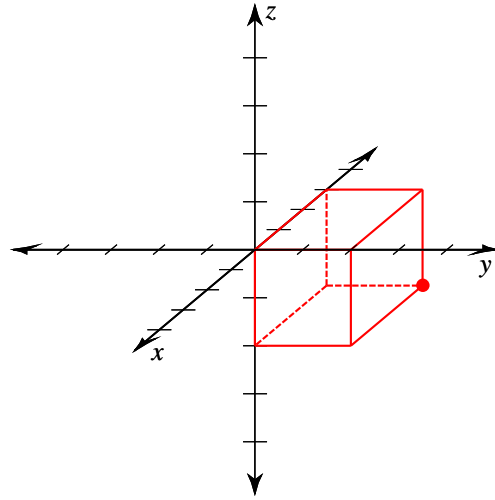

15) $(-4, 3, 0)$

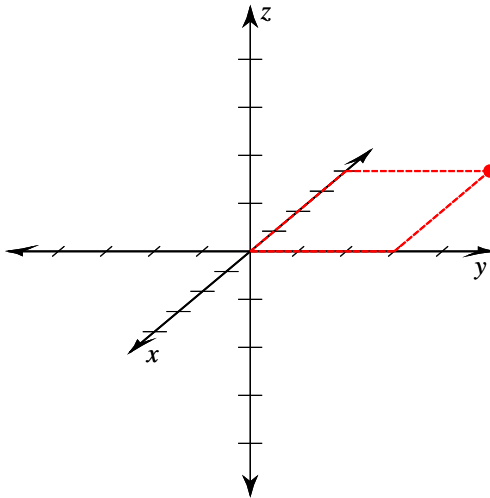

16) $(-4, -4, 3)$

